

Hangzhou Hikrobot Technology Co.,Ltd.

VC2000 Series Vision Controller

User Manual

HIKROBOT

Legal Information

© Hangzhou Hikrobot Co., Ltd. All rights reserved.

About this Manual

The document includes instructions for using and managing the product. Pictures, charts, images and all other information hereinafter are for description and explanation only. The information contained in the document is subject to change, without notice, due to firmware updates or other reasons. Please find the latest version in the company website (<https://en.hikrobotics.com/>). Unless otherwise agreed, Hangzhou Hikrobot Co., Ltd. or its affiliates (hereinafter referred to as “Hikrobot”) makes no warranties, express or implied. Please use the Document with the guidance and assistance of professionals trained in supporting the Product.

Acknowledgment of Intellectual Property Rights

- Hikrobot owns the copyrights and/or patents related to the technology embodied in the Products described in this Document, which may include licenses obtained from third parties. Any part of the Document, including text, pictures, graphics, etc., belongs to Hikrobot. No part of this Document may be excerpted, copied, translated, or modified in whole or in part by any means without written permission.
- **HIKROBOT** and other Hikrobot's trademarks and logos are the properties of Hikrobot in various jurisdictions. Other trademarks and logos mentioned are the properties of their respective owners.
- **HDMI**[™]: The terms HDMI and HDMI High-Definition Multimedia Interface, and the HDMI Logo are trademarks or registered trademarks of HDMI Licensing Administrator, Inc. in the United States and other countries.

Disclaimer

TO THE MAXIMUM EXTENT PERMITTED BY APPLICABLE LAW, THIS MANUAL AND THE PRODUCT DESCRIBED, WITH ITS HARDWARE, SOFTWARE AND FIRMWARE, ARE PROVIDED "AS IS" AND "WITH ALL FAULTS AND ERRORS". HIKROBOT MAKES NO WARRANTIES, EXPRESS OR IMPLIED, INCLUDING WITHOUT LIMITATION, MERCHANTABILITY, SATISFACTORY QUALITY, OR FITNESS FOR A PARTICULAR PURPOSE. THE USE OF THE PRODUCT BY YOU IS AT YOUR OWN RISK. IN NO EVENT WILL HIKROBOT BE LIABLE TO YOU FOR ANY SPECIAL, CONSEQUENTIAL, INCIDENTAL, OR INDIRECT DAMAGES, INCLUDING, AMONG OTHERS, DAMAGES FOR LOSS OF BUSINESS PROFITS, BUSINESS INTERRUPTION, OR LOSS OF DATA, CORRUPTION OF SYSTEMS, OR LOSS OF DOCUMENTATION, WHETHER BASED ON BREACH OF CONTRACT, TORT (INCLUDING NEGLIGENCE), PRODUCT LIABILITY, OR OTHERWISE, IN CONNECTION WITH THE USE OF THE PRODUCT, EVEN IF HIKROBOT HAS BEEN ADVISED OF THE POSSIBILITY OF SUCH DAMAGES OR LOSS.

YOU ACKNOWLEDGE THAT THE NATURE OF INTERNET PROVIDES FOR INHERENT SECURITY RISKS, AND HIKROBOT SHALL NOT TAKE ANY RESPONSIBILITIES FOR ABNORMAL OPERATION, PRIVACY LEAKAGE OR OTHER DAMAGES RESULTING FROM

CYBER-ATTACK, HACKER ATTACK, VIRUS INFECTION, OR OTHER INTERNET SECURITY RISKS; HOWEVER, HIKROBOT WILL PROVIDE TIMELY TECHNICAL SUPPORT IF REQUIRED.

YOU AGREE TO USE THIS PRODUCT IN COMPLIANCE WITH ALL APPLICABLE LAWS, AND YOU ARE SOLELY RESPONSIBLE FOR ENSURING THAT YOUR USE CONFORMS TO THE APPLICABLE LAW. ESPECIALLY, YOU ARE RESPONSIBLE, FOR USING THIS PRODUCT IN A MANNER THAT DOES NOT INFRINGE ON THE RIGHTS OF THIRD PARTIES, INCLUDING WITHOUT LIMITATION, RIGHTS OF PUBLICITY, INTELLECTUAL PROPERTY RIGHTS, OR DATA PROTECTION AND OTHER PRIVACY RIGHTS. YOU SHALL NOT USE THIS PRODUCT FOR ANY PROHIBITED END-USES, INCLUDING THE DEVELOPMENT OR PRODUCTION OF WEAPONS OF MASS DESTRUCTION, THE DEVELOPMENT OR PRODUCTION OF CHEMICAL OR BIOLOGICAL WEAPONS, ANY ACTIVITIES IN THE CONTEXT RELATED TO ANY NUCLEAR EXPLOSIVE OR UNSAFE NUCLEAR FUEL-CYCLE, OR IN SUPPORT OF HUMAN RIGHTS ABUSES.

THE PERFORMANCE DATA IN THIS PUBLICATION IS BASED ON HIKROBOT'S INTERNAL RESEARCH/EVALUATION. ACTUAL DATA MAY VARY DEPENDING ON SPECIFIC CONFIGURATIONS AND OPERATING CONDITIONS AND HIKROBOT SHALL NOT BEAR THE CONSEQUENCES ARISING THEREFROM.

IN THE EVENT OF ANY CONFLICTS BETWEEN THIS MANUAL AND THE APPLICABLE LAW, THE LATTER PREVAILS.

Regulatory Information

Note

These clauses apply only to the products bearing the corresponding mark or information.

EU Conformity Statement



This product and - if applicable - the supplied accessories too are marked with "CE" and comply therefore with the applicable harmonized European standards listed under the Directive 2014/30/EU (EMCD), Directive 2001/95/EC (GPSD) and Directive 2011/65/EU (RoHS).



2012/19/EU (WEEE directive): Products marked with this symbol cannot be disposed of as unsorted municipal waste in the European Union. For proper recycling, return this product to your local supplier upon the purchase of equivalent new equipment, or dispose of it at designated collection points. For more information see: <http://www.recyclethis.info>



2006/66/EC (battery directive): This product contains a battery that cannot be disposed of as unsorted municipal waste in the European Union. See the product documentation for specific battery information. The battery is marked with this symbol, which may include lettering to indicate cadmium (Cd), lead (Pb), or mercury (Hg). For proper recycling, return the battery to your supplier or to a designated collection point. For more information see: <http://www.recyclethis.info>



Korea Certification

A급 기기: 이 기기는 업무용(A급) 전자파적합기기로서 판매자 또는 사용자는 이 점을 주의하시기바라며, 가정 외의 지역에서 사용하는 것을 목적으로 합니다.

Warning: This is a class A product. In a domestic environment this product may cause radio interference in which case the user may be required to take adequate measures.

Symbol Conventions

The symbols that may be found in this document are defined as follows.

Symbol	Description
 Danger	Indicates a hazard with a high level of risk, which if not avoided, will result in death or serious injury.
 Caution	Indicates a potentially hazardous situation which, if not avoided, could result in equipment damage, data loss, performance degradation, or unexpected results.
 Note	Provides additional information to emphasize or supplement important points of the main text.

Available Model

This manual is applicable to the VC2000 series vision controller.

Contact Information

Hangzhou Hikrobot Co., Ltd.
E-mail: global.support@hikrobotics.com
Website: <https://en.hikrobotics.com/>

Contents

Chapter 1 Safety Instruction	1
1.1 Safety Claim	1
1.2 Safety Instruction	1
1.3 Electromagnetic Interference Prevention.....	3
Chapter 2 Overview.....	4
2.1 Introduction.....	4
2.2 Key Feature.....	4
Chapter 3 Appearance	5
Chapter 4 Installation and Access to Device.....	7
4.1 Installation Preparation.....	7
4.2 Install Device.....	7
4.3 Connect Device	10
4.4 Access to Device	10
Chapter 5 Interface Description	12
5.1 GPIO Interface.....	12
5.1.1 Pin Definition	12
5.1.2 Opto-Isolated Input Wiring.....	13
5.1.3 Opto-Isolated Output Wiring.....	15
5.2 Serial Port	16
5.3 Power Interface.....	18
Chapter 6 Demonstration Tool	19
6.1 Serial Port Connection Settings.....	19
6.1.1 Set Connection	19
6.1.2 View Message Window	19
6.2 RS-232/485/422 Settings	20
6.3 Light Source Settings	20
6.4 IO Settings	21
6.5 Other Function Settings	23

Chapter 7 System Reinstallation	24
Chapter 8 FAQ (Frequently Asked Question)	25
8.1 What should I do if the external device does not have a VGA interface?.....	25
8.2 Why the monitor screen is black?.....	25
8.3 Why remote desktop connection fails, and user name and password are incorrect?.....	25
8.4 Why the system is blue screen or crashes, or frequent reboots?	26
8.5 Why there is no signal feedback of GPIO input and electrical level change?	26

Chapter 1 Safety Instruction

The safety instructions are intended to ensure that the user can use the device correctly to avoid danger or property loss. Read and follow these safety instructions before installing, operating and maintaining the device.

1.1 Safety Claim

- To ensure personal and device safety, when installing, operating, and maintaining the device, follow the signs on the device and all safety instructions described in the manual.
- The note, caution and danger items in the manual do not represent all the safety instructions that should be observed, but only serve as a supplement to all the safety instructions.
- The device should be used in an environment that meets the design specifications, otherwise it may cause malfunctions, and malfunctions or component damage caused by non-compliance with relevant regulations are not within the scope of the device's quality assurance.
- Our company will not bear any legal responsibility for personal safety accidents and property losses caused by abnormal operation of the device.

1.2 Safety Instruction

Caution

- Do not install the device if it is found that the device and accessories are damaged, rusted, water ingress, model mismatch, missing parts, etc., when unpacking.
- Avoid storage and transportation in places such as water splashing and rain, direct sunlight, strong electric fields, strong magnetic fields, and strong vibrations.
- Avoid dropping, smashing or vigorously vibrating the device and its components.
- It is forbidden to install the indoor device in an environment where it may be exposed to water or other liquids. If the device is damp, it may cause fire and electric shock hazard.
- Place the device in a place out of direct sunlight and ventilation, away from heat sources such as heaters and radiators.
- Install the device in a stable position. Otherwise, dumping may cause serious personal injury or death.
- In the use of the device, you must be in strict compliance with the electrical safety regulations of the nation and region.
- Use the power adapter provided by the official manufacturer. The power adapter must meet the Limited Power Source (LPS) requirements. For specific requirements, please refer to the device's technical specifications.
- Do not cover the device's plug or outlet for disconnecting power supply.
- It is strictly forbidden to wire, maintain, and disassemble the device is powered on.

Otherwise, there is a danger of electric shock.

- This is a Class A device. In the living environment, this device may cause radio interference. In this case, the user may be required to take practical measures against the interference.
- Make sure that the device is installed in good condition, the wiring is firm, and the power supply meets the requirements before powering on the device.
- Avoid powering off the device by plugging and unplugging the power cord directly if the device has a power switch.
- If the device emits smoke, odor or noise, please turn off the power and unplug the power cord immediately, and contact the dealer or service center in time.
- It is strictly forbidden to touch any terminal of the device when operating it. Otherwise there is a danger of electric shock.
- It is strictly forbidden for non-professional technicians to detect signals during device operation, otherwise it may cause personal injury or device damage.
- It is strictly forbidden to maintain the device is powered on. Otherwise, there is a danger of electric shock.
- If the device does not work properly, please contact your dealer or the nearest service center. Never attempt to disassemble the device yourself. We shall not assume any responsibility for problems caused by unauthorized repair or maintenance.
- Caution: If the device has battery, risk of explosion if battery is replaced by an incorrect type. Dispose of used batteries according to the instructions.
- Please dispose of the device in strict accordance with the relevant national or regional regulations and standards to avoid environmental pollution and property damage.

Note

- Check whether the device's package is in good condition, whether there is damage, intrusion, moisture, deformation, etc. before unpacking.
- Check the surface of the device and accessories for damage, rust, bumps, etc. when unpacking.
- Check whether the quantity and information of the device and accessories are complete after unpacking.
- Store and transport the device according to the storage and transport conditions of the device, and the storage temperature and humidity should meet the requirements.
- It is strictly prohibited to transport the device in combination with items that may affect or damage the device.
- Quality requirements for installation and maintenance personnel:
 - Qualification certificate or working experience in weak current system installation and maintenance, and relevant working experience and qualifications. Besides, the personnel must possess the following knowledge and operation skills.
 - The basic knowledge and operation skills of low voltage wiring and low voltage electronic circuit connection.
 - The ability to comprehend the contents of this manual.
- Please read the manual and safety instructions carefully before installing the device.
- Please install the device strictly according to the installation method in this manual.
- The case of the device may be overheated, and it needs to be powered off for half an hour

before it can be touched.

- The device should not be placed with exposed flame sources, such as lighted candles.

1.3 Electromagnetic Interference Prevention

- Make sure that the shielding layer of cables is intact and 360° connected to the metal connector when using shielded cables.
- Do not route the device together with other equipment (especially servo motors, high-power devices, etc.), and control the distance between cables to more than 10 cm. Make sure to shield the cables if unavoidable.
- The control cable of the device and the power cable of the industrial light source must be wired separately to avoid bundled wiring.
- The power cable, data cable, signal cable, etc. of the device must be wired separately. Make sure to ground them if the wiring groove is used to separate the wiring and the wiring groove is metal.
- During the wiring process, evaluate the wiring space reasonably, and do not pull the cables hard, so as not to damage the electrical performance of the cables.
- If the device is powered on and off frequently, it is necessary to strengthen the voltage isolation, and consider adding a DC/DC isolation power supply module between the device and the adapter.
- Use the power adapter to supply power to the device separately. If centralized power supply is necessary, make sure to use a DC filter to filter the power supply of the device separately before use.
- The unused cables of the device must be insulated.
- When installing the device, if you cannot ensure that the device itself and all equipment connected to the device are well grounded, you should isolate the device with an insulating bracket.
- To avoid the accumulation of static electricity, ensure that other equipment (such as machines, internal components, etc.) and metal brackets on site are properly grounded.
- During the installation and use of the device, high voltage leakage must be avoided.
- Use a figure-eight bundle method if the device cable is too long.
- When connecting the device and metal accessories, they must be connected firmly to maintain good conductivity.
- Use a shielded network cable to connect to the device. If you use a self-made network cable, make sure that the shielding shell at the aviation head is well connected to the aluminum foil or metal braid of the shielding cable.

Chapter 2 Overview

2.1 Introduction

The VC2000 series vision controller adopts Intel® Elkhart Lake processor and has multiple interfaces like GigE, USB 2.0, and USB 3.0. The vision controller has compact structure with stable performance, provides solutions for vision applications, and is widely applicable to consumer electronics, food and pharmaceutical, machining, other industries, etc.

2.2 Key Feature

- Adopts Intel® Elkhart Lake processor to provide calculation.
- Supports GPIO function.
- Supports 4-channel light source control.
- Adopts Intel® GigE interfaces for stable data transmission.
- Built-in USB interface or dongle is optional.

 **Note**

- The specific functions may differ by device models.
 - Refer to the device's datasheet for specific parameters.
-

Chapter 3 Appearance

Note

- For specific appearance and dimension, please refer to the device's datasheet for details.
- The appearance is subject to change, and the actual device you purchased shall prevail.

The VC2000 series vision controller has two types, including device with I/O and 4-channel light source, and device without I/O and 4-channel light source. Their appearance is shown below.

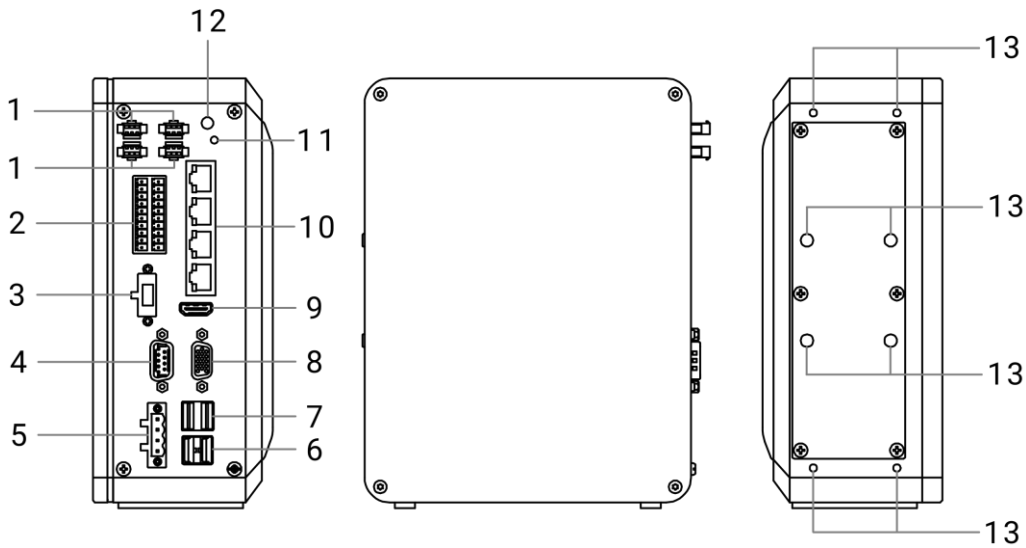

Figure 3-1 Device with I/O and 4-Channel Light Source

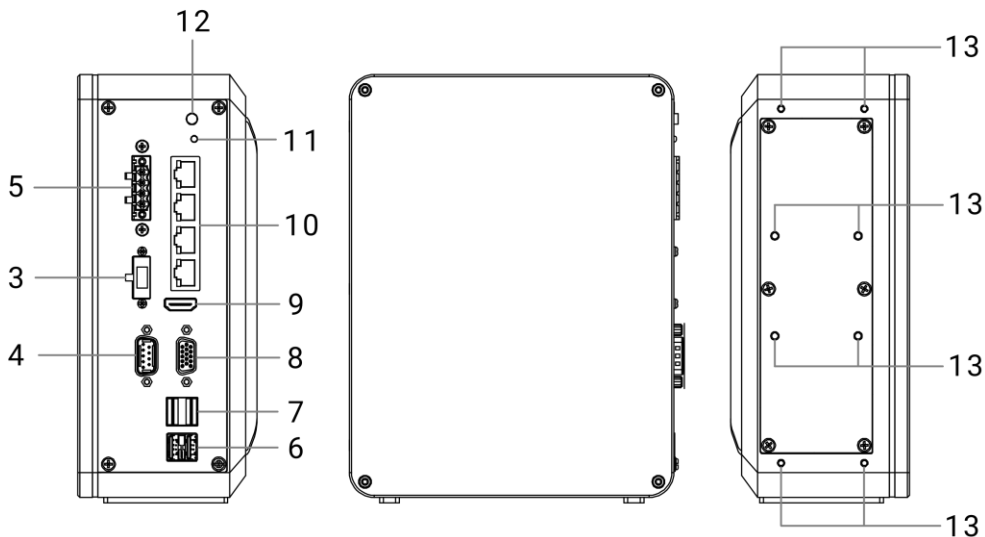



Figure 3-2 Device without I/O and 4-Channel Light Source

Table 3-1 Component Description

No.	Name	Description
1	Light Source Interface	It is used to connect light source and its brightness.  Note Device without I/O and 4-channel light source does not have a light source interface.
2	GPIO Interface	It provides input and output function, and you should use GPIO cable to connect it.  Note Device without I/O and 4-channel light source does not have a GPIO interface.
3	Remote Switch Interface	It is used to power on/off the device remotely.
4	Serial Port	It is used for RS-232 serial communication, supporting switching to RS-485 or RS-422.
5	Power Interface	It provides power supply.
6	USB 2.0 Interface	It is used to connect USB flash drive, portable HDD, etc.
7	USB 3.0 Interface	It is used to connect USB flash drive, portable HDD, etc.
8	VGA Interface	It is used to transmit video signal.
9	HDMI Interface	It is used to transmit audio and video signals.
10	GigE Interface	It is used to transmit network signal.
11	Power Indicator	It indicates device power status. The indicator is solid red when the device is switched on.
12	Restart Switch	It is used to restart the device.
13	Screw Hole	It is used to fix the device to the mounting plate.

Chapter 4 Installation and Access to Device

4.1 Installation Preparation

You need to prepare following accessories before installation.

Table 4-1 Accessories

No.	Name	Quantity	Description
1	Power Adapter	1	It refers to the suitable power adapter that is included in the package.
2	GPIO Cable	1	It refers to the supplied GPIO cable that is included in the package.
3	Mounting Plate	2	It is used to fix device to other mechanical structures, and is included in the package.
4	Screws	Several	They are used to fix the device, and are included in the package.
5	Bracket	1	It is used to fix the device and Din35 slide rail, and you need to purchase it separately.

4.2 Install Device

You should install the device before using it. The device supports two installation methods, including installation via screw hole and installation via slide rail. You should select the installation method according to actual demands.

Before You Start

- Make sure that the device in the package is in good condition and all accessories are included.
- Make sure that all related devices are powered off during the installation.

Note

The appearance is subject to change, and the actual device you purchased shall prevail.

Place on Workbench

You can directly place the device on a workbench for usage, as shown below.

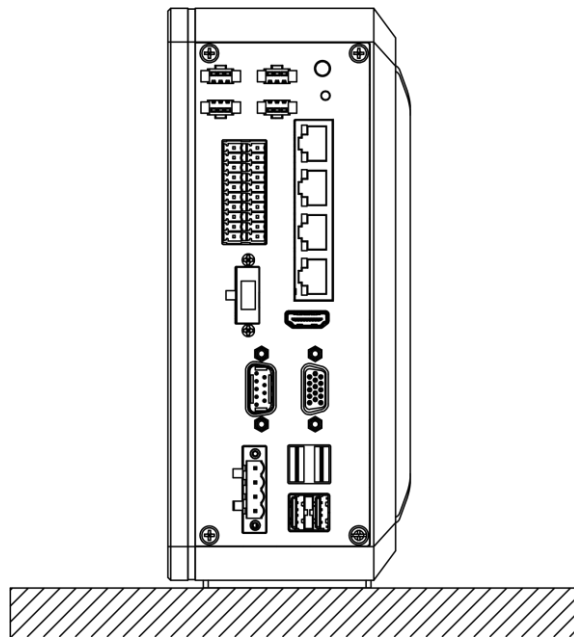

Figure 4-1 Place on Workbench

Installation via Screw Hole

Use four M6 hexagon socket bolts and four M6 nuts to fix the device to a mounting plate, as shown below.

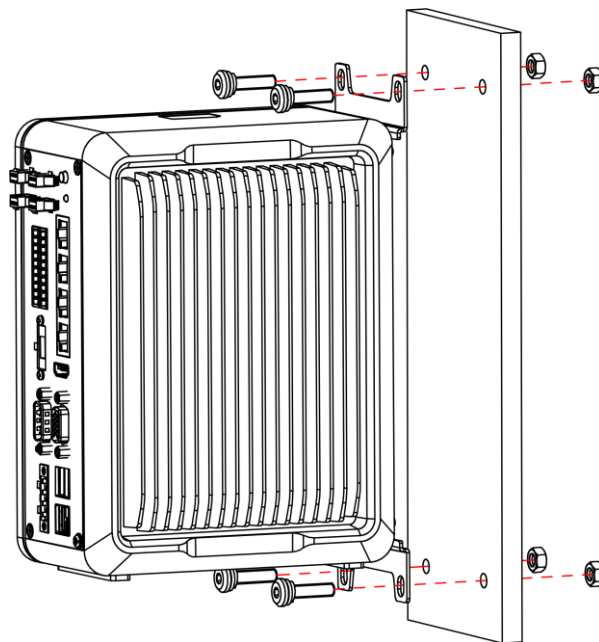

Figure 4-2 Installation via Screw Hole

Installation via Slide Rail

The device supports installing via standard Din35 slide rail.

Steps

1. Use four M3 screws to fix a bracket to the device, as shown below.

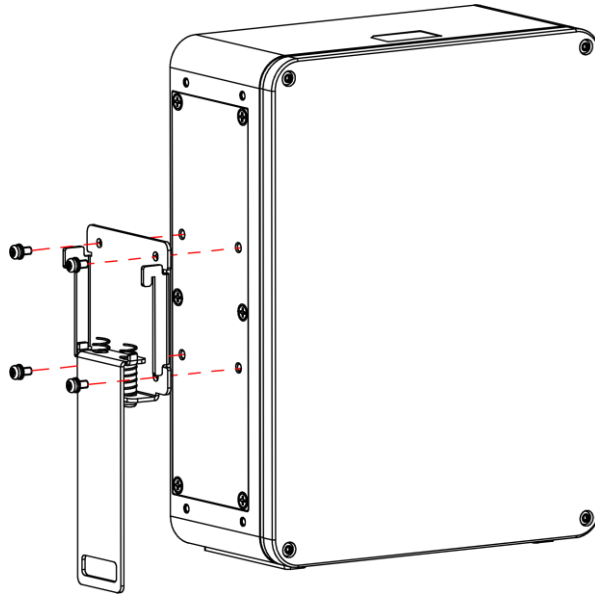

Figure 4-3 Fix Bracket

2. Pull the pallet of the bracket downward, and insert Din35 slide rail into the bracket's slide rail slot, as shown below.

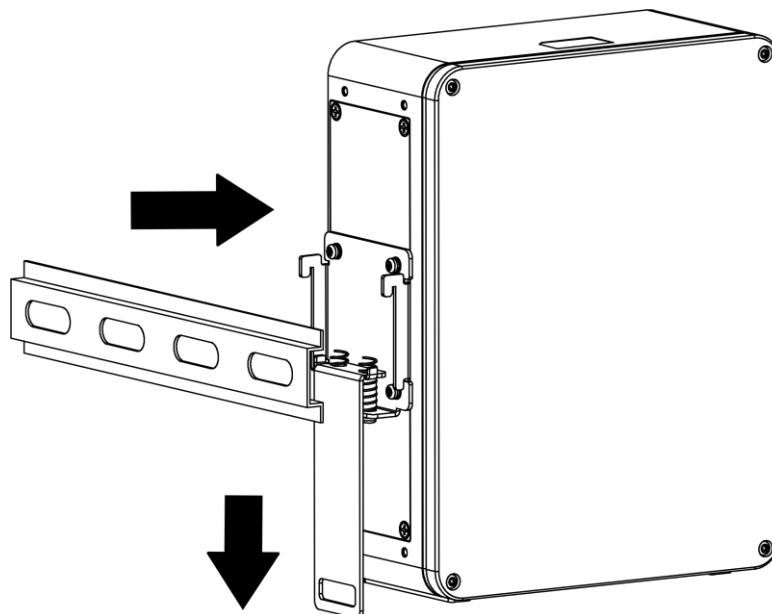

Figure 4-4 Insert Din35 Slide Rail

3. Push the pallet of the bracket upward and make sure that Din35 slide rail is fixed firmly.

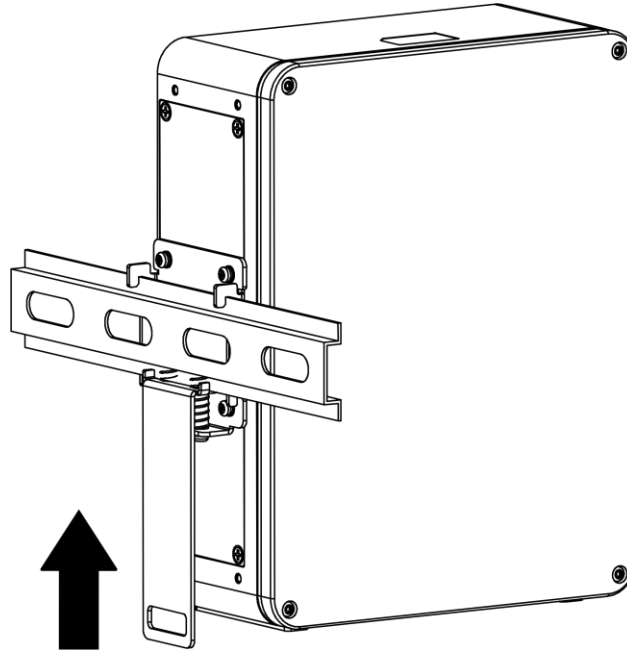

Figure 4-5 Fix Slide Rail

4.3 Connect Device

Steps

1. Insert external light sources to the device's light source interface according to actual demands.

Note

Device without I/O and 4-channel light source does not have a light source interface.

2. Use power cord to connect the device to a power supply via the power interface.
3. Use serial port cable to connect the device to a PC via the device's serial port.

Note

The device's serial port is RS-232 communication by default, but you can configure it to RS-485 or RS-422. Refer to section **Serial Port** for details.

4.4 Access to Device

You can operate the device on the monitor by connecting them via HDMI, or you can remotely access the device via the PC that is in the same network segment with the device.

Note

- The default user name of the device is **Administrator**, and the password is **Operation666**
 - For security, it is highly recommended to change the default password for the first-time use.
-

Chapter 5 Interface Description

5.1 GPIO Interface

5.1.1 Pin Definition

The device's GPIO interface has 20 pins, and you can refer to the following table for pin definitions.

Note

Device without I/O and 4-channel light source does not have a GPIO interface.

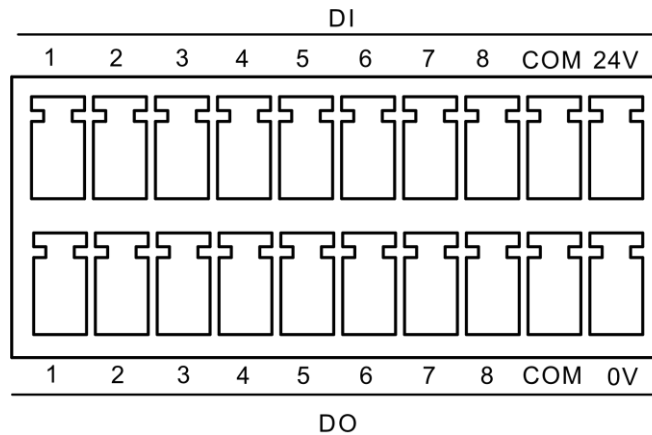

Figure 5-1 GPIO Interface

Table 5-1 Pin Definitions of GPIO Interface

Pin No.	Signal Name	Description	Screen Printing	Pin No.	Signal Name	Description	Screen Printing
1	DI1	Opto-isolated input 1	1	11	DO1	Opto-isolated output 1	1
2	DI2	Opto-isolated input 2	2	12	DO2	Opto-isolated output 2	2
3	DI3	Opto-isolated input 3	3	13	DO3	Opto-isolated output 3	3
4	DI4	Opto-isolated input 4	4	14	DO4	Opto-isolated output 4	4
5	DI5	Opto-isolated input 5	5	15	DO5	Opto-isolated output 5	5
6	DI6	Opto-isolated input 6	6	16	DO6	Opto-isolated output 6	6
7	DI7	Opto-isolated input 7	7	17	DO7	Opto-isolated output 7	7

Pin No.	Signal Name	Description	Screen Printing	Pin No.	Signal Name	Description	Screen Printing
8	DI8	Opto-isolated input 8	8	18	DO8	Opto-isolated output 8	8
9	COM	Input common port (without polarity)	COM	19	COM	Output common port (without polarity)	COM
10	PWR	Output 24 V	24 V	20	GND	Output power ground	0 V

5.1.2 Opto-Isolated Input Wiring

The device can receive input signal sent by external devices via its GPIO interface.

Note

- Input wiring may differ by external device type. Here we take DI8 signal as an example to introduce input wiring.
- The voltage of VCC should not be large than 24 V. Otherwise, the output signal exception may occur.
- Do not connect the device's power interface to other interfaces. Otherwise, short circuit may occur.

PNP Device as Input Signal

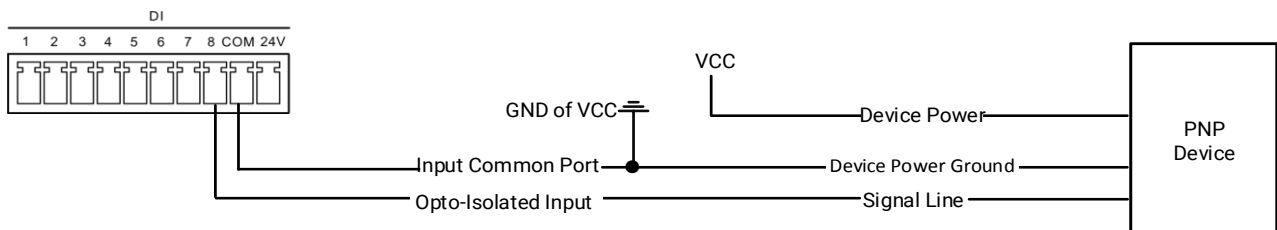

Figure 5-2 Input Signal Connecting PNP Device (I)

The wiring is as following if the device's PWR and GND are used to power the external device. The power supply is 24 V and max. output current is 150 mA.

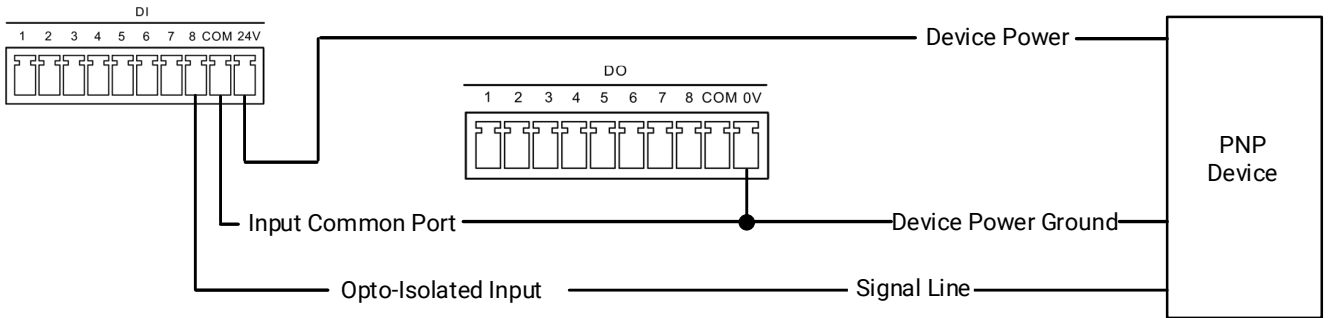

Figure 5-3 Input Signal Connecting PNP Device (II)

NPN Device as Input Signal

The wiring is as following if the VCC of NPN device is 12 V or 24 V and without external resistance.

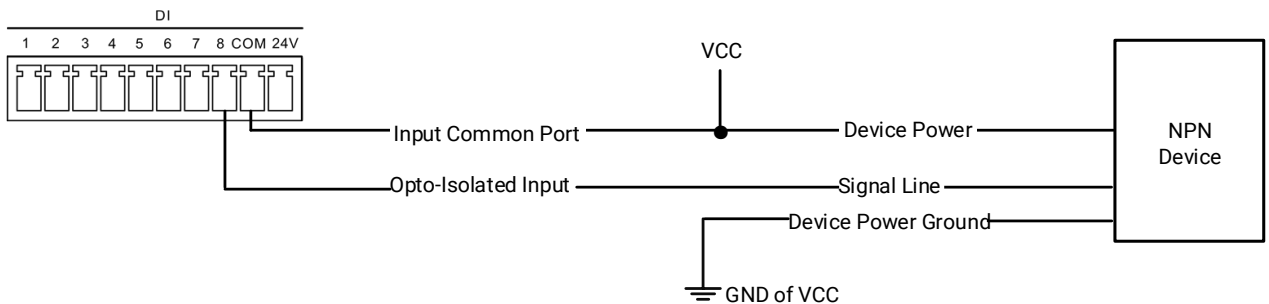

Figure 5-4 Input Signal Connecting NPN Device without External Resistance

The wiring is as following if the VCC of NPN device is 12 V or 24 V and with pull-up resistance.

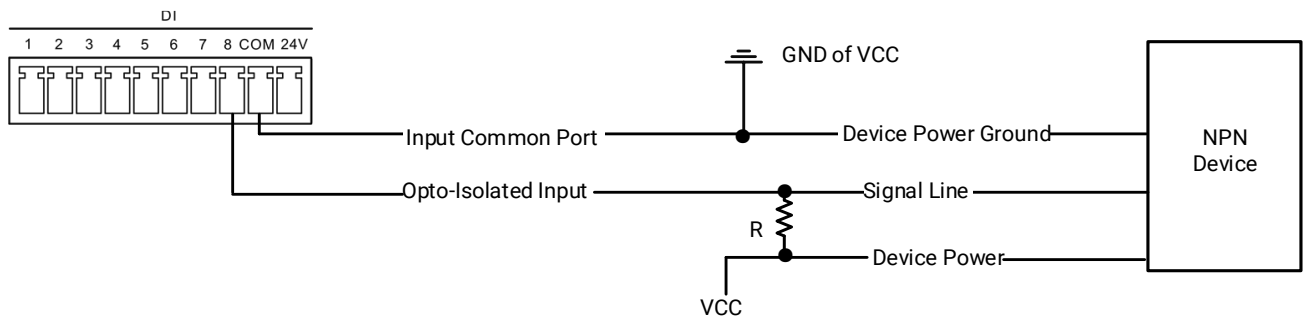

Figure 5-5 Input Signal Connecting NPN Device with Pull-Up Resistance

The resistance value (R) in figure above is different when the VCC of the device changes. Refer to the table below for details.

Table 5-2 Relation between VCC and Resistance

VCC	R
12 VDC	1 KΩ
24 VDC	4.7 KΩ

5.1.3 Opto-Isolated Output Wiring

The device can send output signal to external devices via its I/O interface.

Note

- Output wiring may differ by external device type. Here we take DO8 signal as an example to introduce input wiring.
- The voltage of VCC should not be large than 24 V. Otherwise, the output signal exception may occur.
- Do not connect the device's power interface to other interfaces. Otherwise, short circuit may occur.

PNP Device as External Device

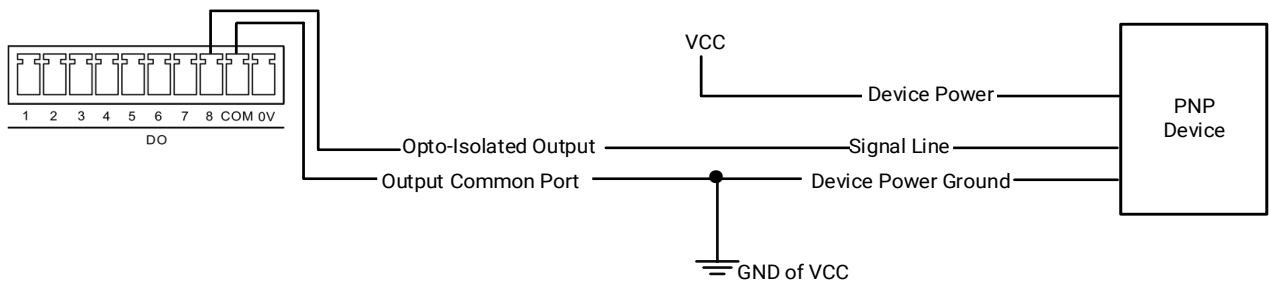

Figure 5-6 Output Signal Connecting PNP Device (I)

The wiring is as following if the digital light controller's PWR and GND are used to power the external device. The power supply is 24 V and max. output current is 150 mA.

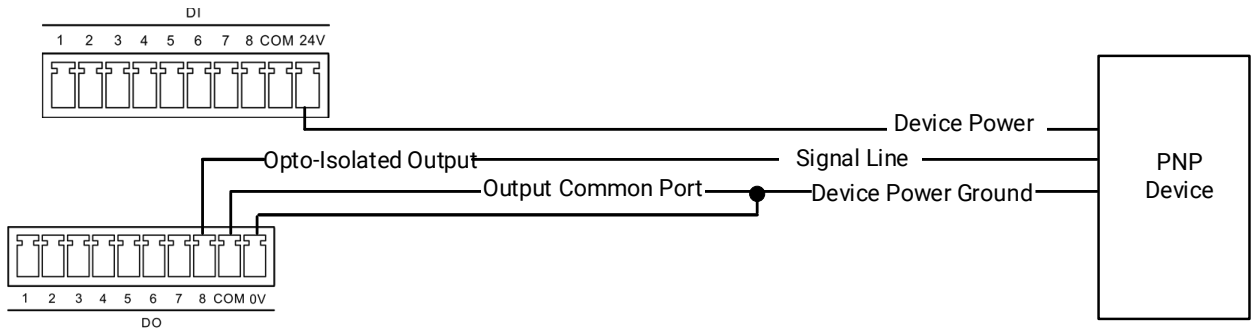

Figure 5-7 Output Signal Connecting PNP Device (II)

NPN Device as External Device

The wiring is as following if the VCC of NPN device is 12 V or 24 V and without external resistance.

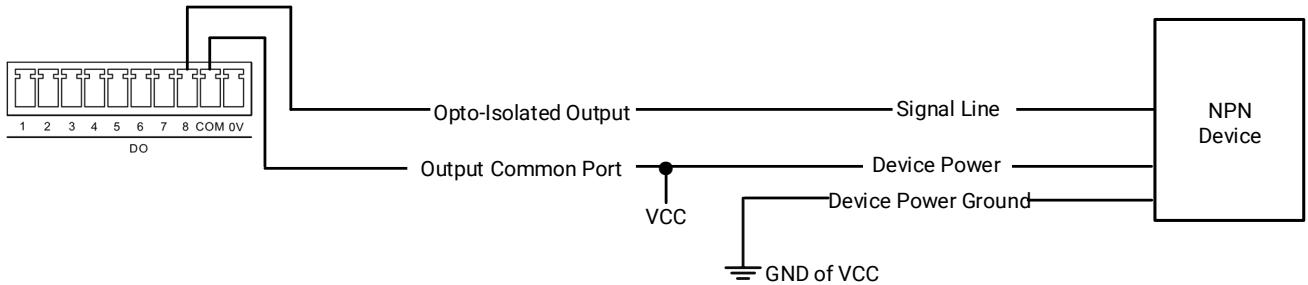

Figure 5-8 Output Signal Connecting NPN Device without External Resistance

The wiring is as following if the VCC of NPN device is 12 V or 24 V and with pull-up resistance.

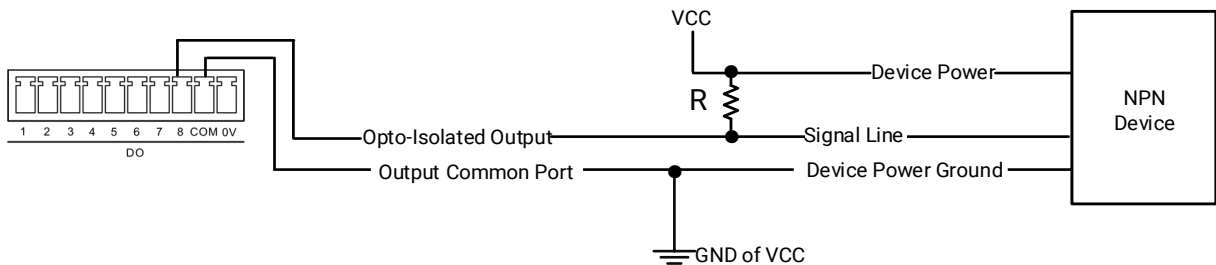

Figure 5-9 Output Signal Connecting NPN Device with Pull-Up Resistance

The resistance value (R) in figure above is different when the VCC of the device changes. Refer to the table below for details.

Table 5-3 Relation between VCC and Resistance

VCC	R
12 VDC	1 K Ω
24 VDC	4.7 K Ω

5.2 Serial Port

The device has a standard D-sub 9-pin communication interface. The serial port is RS-232 by default, and supports switching to RS-485 or RS-422 via BIOS settings.

Steps

1. Power on the device, and press **DELETE** to enter BIOS setting window.
2. Go to **Advanced** → **SFB Chipset Feature** → **SIO UART0 Transfer Mode**, and set it as **RS485** or **RS422**.

Refer to the following table for the pin definitions.

Note

RS-232 is not a full functional serial port, and only pin 2, 3 and 5 are available.

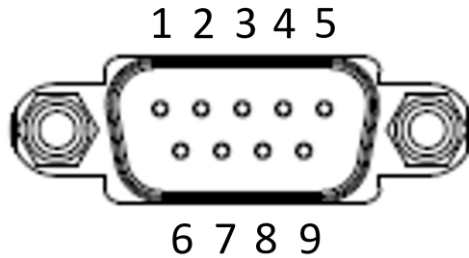

Figure 5-10 Serial Port

Table 5-4 RS-232 Pin Definitions

Pin No.	Description	Pin No.	Description
1	DCD	6	DSR
2	SIN	7	RTS
3	SOUT	8	CTS
4	DTR	9	RI
5	GND	--	--

Table 5-5 RS-422 Pin Definitions

Pin No.	Description
1	TX(B)
2	TX(A)
3	RX(A)
4	RX(B)
5	GND

Table 5-6 RS-485 Pin Definitions

Pin No.	Description
1	D-
2	D+
5	GND

5.3 Power Interface

The device's power interface is used to connect the power adapter, and the power interface is a 2-pin connector. On the left side of the power interface is 24 V, and you can connect power supply positive. On the right side is 0 V, and you can connect power supply negative.

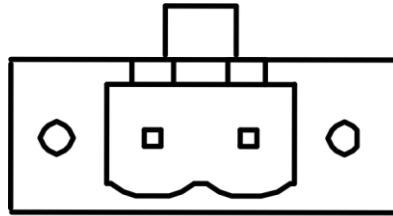

24V 0V

Figure 5-11 Power Interface

Chapter 6 Demonstration Tool

You can use the controller software as demonstration tool to set parameters of the device.

Note

The GUI of the controller software may differ by its version or device's firmware.

6.1 Serial Port Connection Settings

6.1.1 Set Connection

The serial port connection settings allow you to connect the device to the controller software. You can set the corresponding serial port No., baud rate, data bit, stop bit, and parity bit, and click **Connect**.

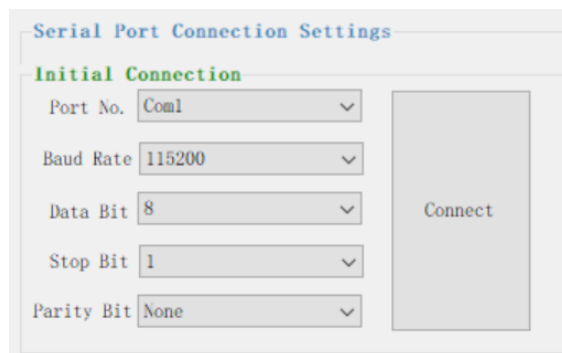

Figure 6-1 Set Connection

Note

After successful connection, other modules of the controller software will be available.

6.1.2 View Message Window

The message window displays logs of the demonstration tool in real time. You can click **Clear** or **Save** to clear or save messages in TXT format.

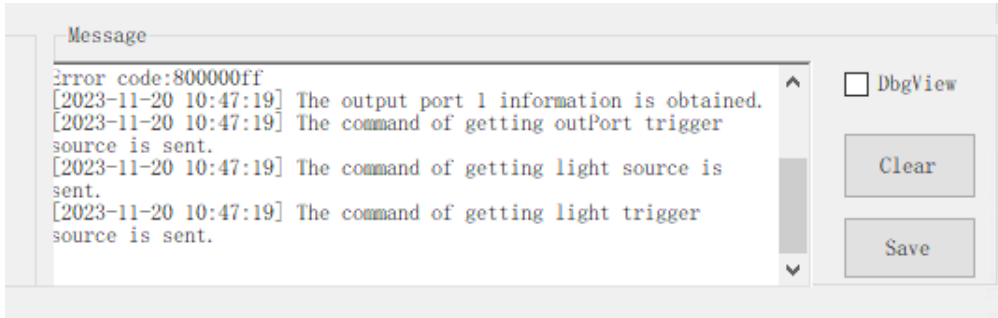

Figure 6-2 Message Window

6.2 RS-232/485/422 Settings

The demonstration tool supports selecting different device types and serial port types. Go to **RS232/485/422 Settings** → **Hard Type**, select corresponding device type according to actual demands, select COM and click **Apply**.

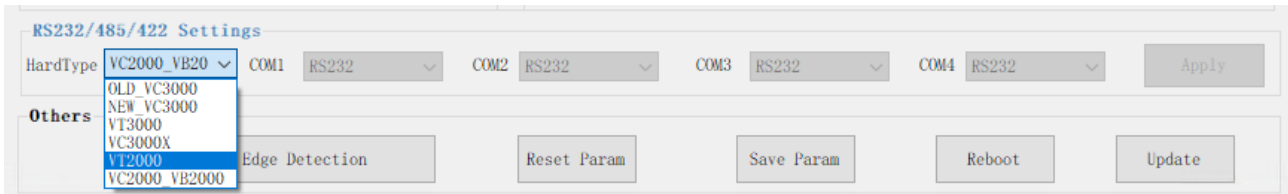

Figure 6-3 Device Type

6.3 Light Source Settings

The demonstration tool supports setting parameters of external light sources. You can select specific light source port, set its duration and brightness, etc.

Note

- Make sure that the light source has been connected to the device's light source interface.
- You should select the corresponding device in **Hard Type** before setting the light source.
- **Port:** It selects the corresponding trigger port of the light source.
- **Duration:** It sets the duration of the light source after triggering.

Note

If the duration is 0, the light source will turn on or turn off according to the trigger signal. If the trigger signal persists, the light source will be solid. If the trigger signal disappears, the light source will be turned off.

- **Brightness:** It sets the brightness of the light source.
- **Status:** It includes **On**, **Off** or **Trigger**. You need to set **Trigger Input** if you select **Trigger** as **Status**.

- **Trigger Signal:** It includes **Rising Edge** or **Falling Edge**.
- **Trigger Input:** It sets trigger input signal source of the light source, and is valid only when the **Status** is **Trigger**. After setting **Trigger Input**, you need to click **Trigger Apply**.

Go to **Light Source Settings**, select **Port**, and set **Duration** and **Brightness** according to actual demands.

Regarding **Status**, you can check **On**, **Off** or **Trigger** to let the light source turn on or turn off after receiving a trigger signal that can be **Rising Edge** or **Falling Edge**. Click **Apply** after setting light source parameters.

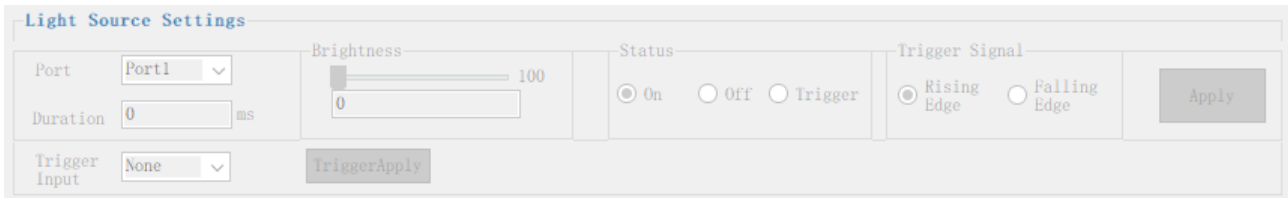

Figure 6-4 Light Source Settings

6.4 IO Settings

The IO settings allow you to set the input and output parameters of the device. You can detect the electrical level of the input signal, select the output port and the output mode, and enable output, etc.

Note

You should select the corresponding device (**VT2000**) in **Hard Type** before setting the IO.

Input Settings

Select **Port**, set **Trigger Signal**, and **Upload Signal** according to actual demands. Enter **Trigger Delay** and **Debouncer Time** to delay the trigger signal received time, and to filter out unwanted short input signals respectively. Click **Apply** after settings.

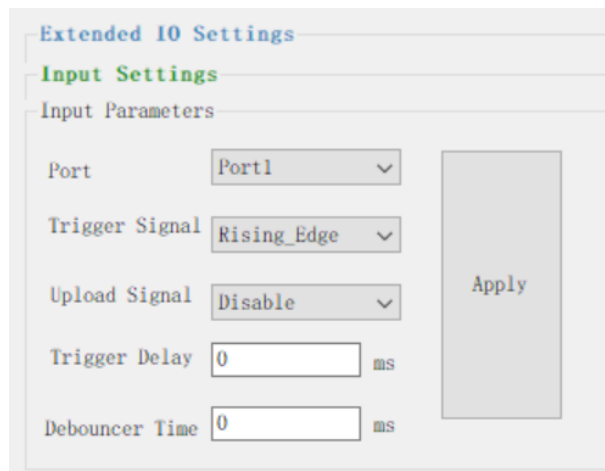

Figure 6-5 Input Settings

Input Detection

Click **Detect** in **Input Signal Detection** to get the electrical level of the input port. Red color stands for the high electrical level, and green color stands for the low electrical level.

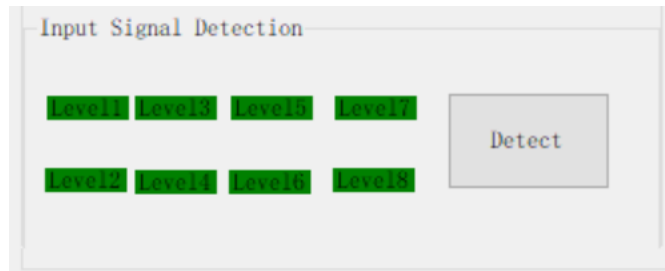

Figure 6-6 Input Detection

Output Settings

In **Output Settings**, you can set these parameters: **Polarity**, **Trigger Input**, **Port**, **Mode**, **Electrical Level**, **Duration**, **Pulse Period**, and **Pulse Width**. Click **Save** after settings.

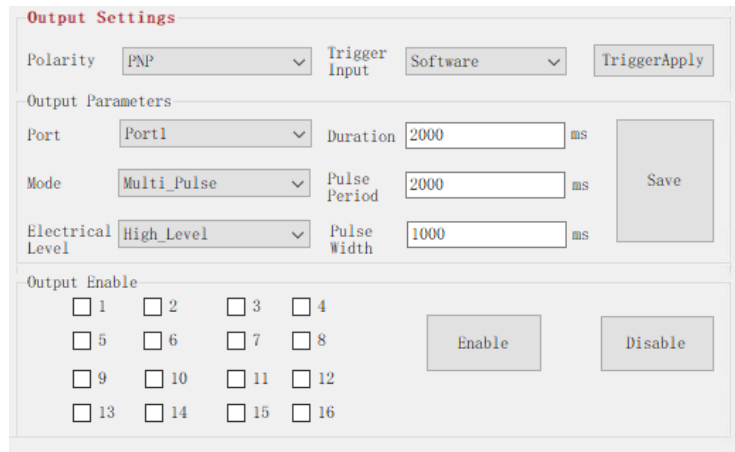

Figure 6-7 Output Settings

Note

Pulse Period and **Pulse Width** are only available when you select **Multipulse** as **Mode**.

After above-mentioned settings, if you want to let the port output signals, you should check the specific port No., and click **Enable**. Otherwise, click **Disable** instead.



Figure 6-8 Enable Output

6.5 Other Function Settings

You can click **Enable Edge Detection** to view the input edge signals and its quantity via **Message** window in real time.

Note

The **Enable Edge Detection** becomes **Disable Edge Detection** after you click it once, and you can click **Disable Edge Detection** to disable edge detection function.

- You can click **Reset Param** to reset all parameters you configured in demonstration tool.
- You can click **Save Param** to save currently configured parameters.
- You can click **Reboot** to reboot the device.
- You can click **Update** to update the device's firmware.



Figure 6-9 Other Function Settings

Chapter 7 System Reinstallation

The default system of the device is 64-bit Windows 10. If the system exception occurs, or you need to use other systems, and then system reinstallation is required. You can reinstall system by connecting the vision controller to USB flash disk, USB optical disk driver, mobile hard disk, etc. After connection, you need to set in BIOS as follows.

Steps

1. Power on the device, and press **F7** to enter **Boot Manager** window.
2. Find the USB device you used and start system reinstallation.

Chapter 8 FAQ (Frequently Asked Question)

8.1 What should I do if the external device does not have a VGA interface?

When selecting cables, you can choose the original HDMI to VGA adapter cable, or you can purchase a suitable adapter cable for using.

8.2 Why the monitor screen is black?

Problem

The monitor screen is black.

Solution

- Reconnect the HDMI or VGA cable.
- Reboot the device.
- After rebooting the device, press **Ctrl + Alt + Delete**, and press **Delete** quickly until the screen is turned on.
- Reinstall operating system again. The default system of the device is 64-bit Windows 10. Contact technical support to get system files.

8.3 Why remote desktop connection fails, and user name and password are incorrect?

Problem

The remote desktop connection fails, and user name and password are incorrect.

Solution

- Connect network directly and use packet capture tool to get the device's IP address.
- Connect display and set network as static IP.
- The correct user name and password are **Administrator** and **Operation666**.

8.4 Why the system is blue screen or crashes, or frequent reboots?

Problem

The system is blue screen or crashes, or frequent reboots.

Solution

- Reboot the device.
- Try to solve the problem according to the error codes and hints of blue screen.
- Reinstall operating system again. The default system of the device is 64-bit Windows 10. Contact technical support to get system files.

8.5 Why there is no signal feedback of GPIO input and electrical level change?

Problem

There is no signal feedback of GPIO input and electrical level change.

Solution

- Check if the signal source has any edge signal trigger; check if the parameters are correctly configured (for example, filter parameter, mode configuration delay).
- If the electrical output level does not change, check if the wirings are correct, and check if the parameter settings are enabled.
- Replace the device and check if the IO port is burned out.



HIKROBOT

SHAPE OUR FUTURE INTELLIGENTLY

Hangzhou Hikrobot Technology Co.,Ltd.

E-mail: global.support@hikrobotics.com

Website: <https://en.hikrobotics.com/>

UD36402B